

Overview

- Enables extension of 323 mm and retraction back against the wall
- Infinite positioning of your monitor for the most adequate viewing angle
- Monitor pivot adjustment of 360 degrees (Landscape/Portrait function)
- VESA® FDMI™ standard compliant,
- Easy and stable mounting on a wall surface
- Solid and durable steel construction, powder coated
- Improve ergonomics and comfort at home and in your workplace
- 10 years warranty

Other products



GD01 LCD/TFT Wall Mount

FOR HOME & OFFICE

GD02

Universal LCD/TFT monitor wall-mounted arm (14-22")



GD02 is a LCD/TFT Swing Arm Wall Mount. It increases ergonomics and comfort at workplaces and gives an opportunity to free up desk space. The wall mount is VESA standard compliant with VESA® FDMI™ standard 75x75mm and 100x100mm*.

GD02 LCD/TFT swing arm mounted in desired position, ensures infinite positioning of your monitor for the most adequate viewing angle.

LCD/TFT monitor can be extended 323 mm from the wall and retracted against the wall when it is not longer needed.

*The optional component GDA1 provides a 200x100mm mounting interface.



GD02 Product card

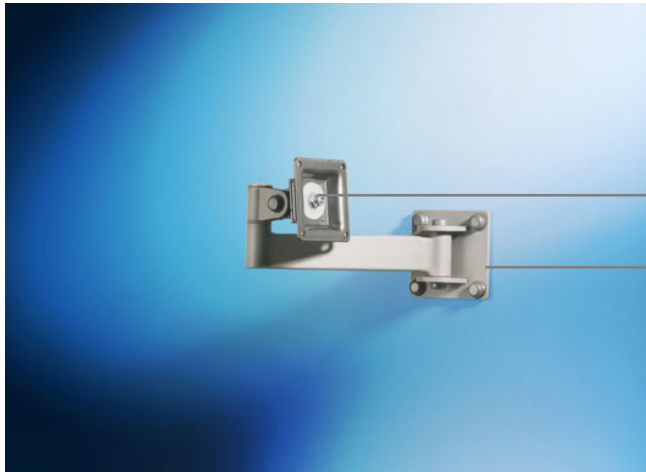

VESA Adapter

Wall mounting plate

Range of movement

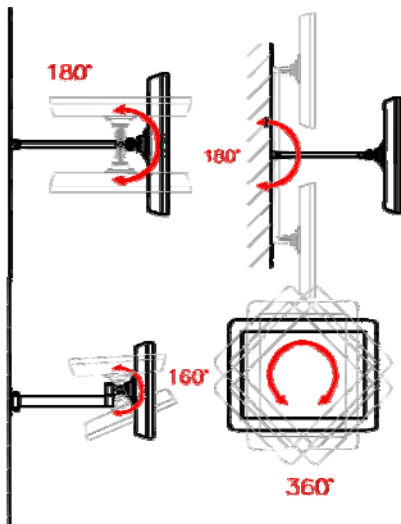

Dimensions

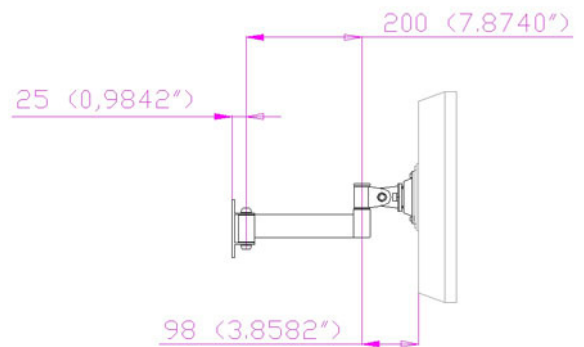

Technical data

Load capacity:	up to 10kg
Mounting interface:	75mm x 75mm
VESA FDMI MIS-D:	100mm x 100mm
Max. / min. distance to the wall	321mm / 121mm
Option GDA1 (not supplied)	200 x 100 mm
Net weight (gross):	1,8 (2,0) kg
Packaging dimensions:	420x130x130mm

Order Code:	Available Colours:	Type of packaging:	EAN product code:
GD02c-B	Black (RAL9005)	Brown	5908252960309
GD02s-B	Silver (RAL9006)	Brown	5908252960316
GDA1s-B	Silver (RAL9006 Glossy)	Brown	5908252960293

© 2006 EDBAK Sp. z o.o.

16.06.2006

EDBAK Sp. z o.o.

Piotrowice 186, 23-107 Strzyżewice
Poland
tel. +48 81 562 81 19
tel./fax +48 81 562 82 90
e-mail: info@edbak.com

www.edbak.com



Quality Management System in compliance with **ISO 9001**.